

# **EUROMAID**

## **OPERATING INSTRUCTIONS**

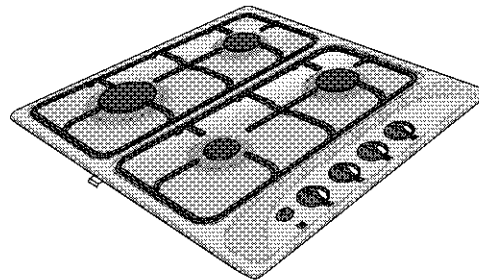

**DOMINO COOKERS  
BUILT-IN HOBS**

Dear Customer,







**It is our ultimate desire that you achieve the best performance from our product, which has been passed through meticulous quality control checks and is manufactured in modern facilities.**

**To this effect, we recommend that you read the entire guide carefully before operating the product and keep it as a reference.**



**Do not operate hob without pan.  
This products are designed only for domestic use.**

## CONTENTS

-  Part 1:  
Safety precautions and important items
  
-  Part 2:  
Technical specifications
  - 2.1. Domino cooktops
  - 2.2. Built-in hobs
  
-  Part 3:  
Important installation and preparation of your cooktop
  - 3.1. Assembly of the cupboard
  
-  Part 4:  
Operating the burners
  - 4.1. Hot plates
  - 4.2. Ceramic plates
  
-  Part 5:  
Maintenance and cleaning
  
-  Part 6:  
Future transportation

## Part 1: Safety precautions and important items

### Electrical installation for ALL ELECTRICAL built-in hobs

Before your appliance is connected to the mains electricity supply, check to ensure that the voltage and the frequency shown in the rating label corresponds with your power supply. The rating label is situated bottom cover of the cooker.

- ☛ If a cable without a plug is provided together with your hob

Connection; ☛ Brown to live wire

☛ Blue to neutral wire

☛ Yellow/green to earth.

- ☛ The mains cable must pass through the cable clamp.

☛ The mains cable should be routed away from the appliance and in particular ventilation slots, the vent outlet and should not be obstructed when pushed into position between the appliance and the wall and/or cabinet.

### Warning! This appliance must be earthed.

- ☛ The earthing cable should always be performed

by a licensed electrician. Our company shall not held responsible for any damage caused by the utilisation of the oven without earthing. If the appliances is connected by a plug, that the plug is easily accessible after installation (but not above the hob).

\*This product must only be installed by a qualified electrician eg. local electricity company with a suitable double pole control unit with a minimum contact clearance of 3 mm in all poles which should be adjacent to (but not above) the cooker in accordance with IEE regulation, Failure to observe this instruction may result in operational problems and invalidation of the product warranty.

**The cable length should be 2 mt max for isolation safety.**

\* If your appliance is supplied without supply cord use schema-I to choose supply cord and use schema-II for installation of cord. Supply cord types are given at below:

Supply cord	2 elect		4 electric /4 ceran		
	mono phase	mono phase	mono phase	Three phase with neutral	Two phase with neutral
H05 RR- F 3G 1,0mm <sup>2</sup>					
H05 RR- F 3G 1,5mm <sup>2</sup>	*	*			
H05 VV- F 3G 2,5mm <sup>2</sup>			*		
H05 VV- F 4G 2,5 mm <sup>2</sup>					*
H05 VV- F 5G 2,5mm <sup>2</sup>				*	

2

schema-II

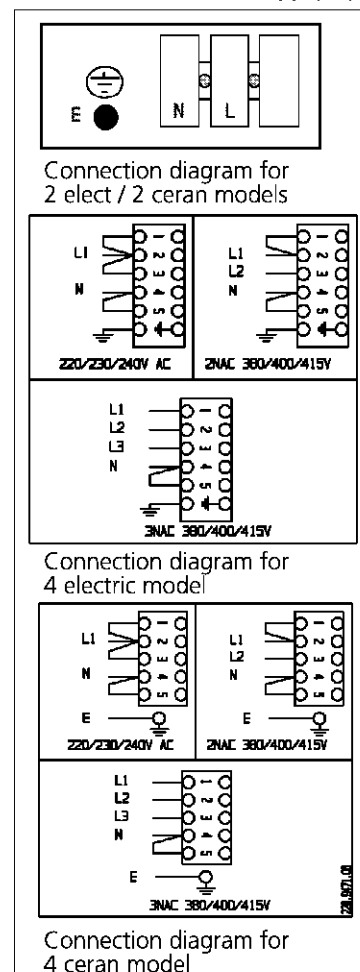

• Before applying to authorized service, have the electrical wiring of your home ready for connection.

• The supply cord must not come in contact with any part of the appliance which is hot during operation.

If the supply cord is damaged, it must be replaced by the manufacturer or its service agent or a similarly qualified person in order to avoid a hazard.

• Always switch off the electrical appliance from the mains when the appliance is not in use, before cleaning or in the unlikely

event of a product failure becoming apparent.

• When using your appliance for the first couple of times, an odour and/or smoke may be emitted which is normal.

• The surfaces of the stainless steel model appliances which are nearer to the burners may change colour because of the excessive heat in the course of time.

• The appliance is not intended for use by young children or infirm persons without supervision.

Young children should be supervised to ensure that they do not play with the appliance.

Before using your product take the packaging materials out.

**The packaging materials can cause danger for the children.**

• Do not use a steam cleaner with to clean this appliance.

**WARNING: To avoid risk of electric shock, immediately switch off the appliance from the mains to avoid the possibility of an electric shock if a crack is detected on the ceramic glass surface.**

## Part 2: Technical specifications

### 2.1. Technical specifications of Domino cookers

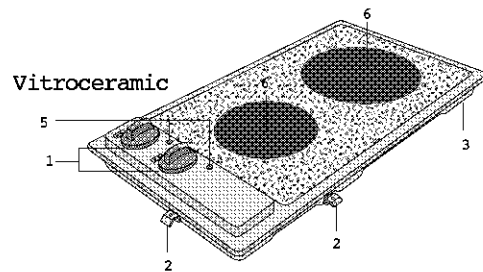
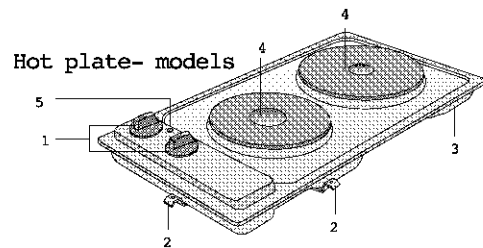

	Electrical models	Vitroceramic models	
Outer width	288 mm	288 mm	
Depth	510 mm	510 mm	
Height	71 mm	71 mm	
<b>Dimension of installation setting</b>			
Width	268 mm	268 mm	
Depth	490 mm	490 mm	
Related fuse settings	16A	16A	
Ø 180 Hot plate	1500 W		
Ø 145 Hot plate	1000 W		
Ø 180 CERAN® hot plate		1700 W	1800 W
Ø 145 CERAN® hot plate		1200 W	1200 W
Total electric power	2500 W	2900 W	3000 W
Total gas power			
Rapid burner			
Auxiliary burner			
Safety device			
Ignition			
Net weight	5 kg	4.5 kg	4.5 kg

- |                     |                     |
|---------------------|---------------------|
| 1. Control knobs    | 4. Hot plate        |
| 2. Assembly clamp   | 5. Indicator light  |
| 3. Protection cover | 6. CERAN® hot plate |

## 2.2. Technical specifications of built-in hobs

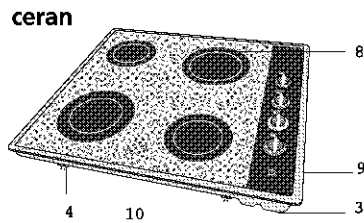
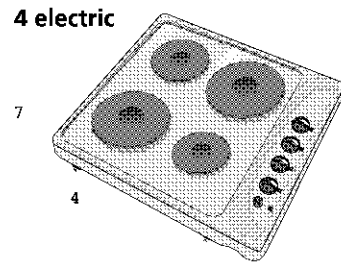

1. Protection cover
2. Assembly clamp
3. Burners' plate
4. Hot plate
5. CERAN® hot plate
6. Indicator light
7. Temperature indicating lights

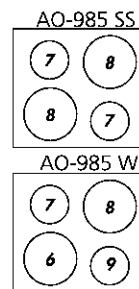

5

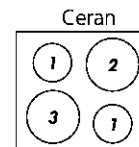

Outer dimensions	
Width	580 mm
Depth	510 mm
Height	71 mm
Dimension of installation setting	
Width	560 mm
Depth	490 mm
Net weight	8 kg
all electric and ceran models	

There may also be plate location other than the ways shown in the figures.

The fast radian, extended and dual plates burn with that brilliant light when they are first ON.

Rapid heating solid plates are denoted by a red spot in the centre of the plate.

The voltage, frequency and maximum powers shown in the rating label .

1	∅140 1200 W Radian plate
2	∅ 180 1700 W Radian plate
3	∅ 110-180 1700 W dual plate
4	∅ 180 1800 W Fast radian plate
5	∅ 170x265 2400 W extended
6	∅ 180 2000 W Fast solid plate
7	∅ 145 1000 W Solid plate
8	∅ 180 1500 W Solid plate
9	∅ 145 1500 W Fast solid plate

## Part 3: Important installation and preparation of your cooker

### 3.1. Assembly of the cupboard

**Installation of hobs with frames:** Remove the band tape on the sealing gasket from the packaging material and stick it around the frame from the bottom.

**for all models:** Assemble your cooker to the counter with the assembly clamp. The way of using the assembly clamp according to the thickness of your counter is shown in the figures unless the flexible (not metallic) assembly handcuff is mounted under the product. Board is to be installed underneath the hobs.

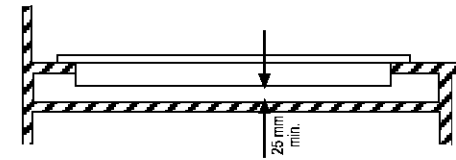
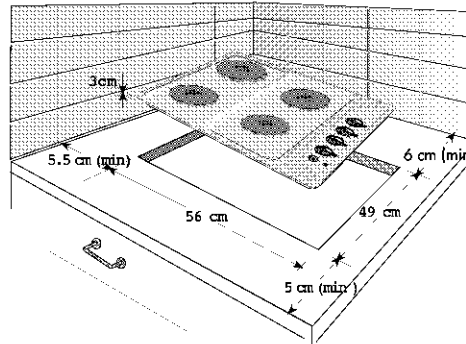
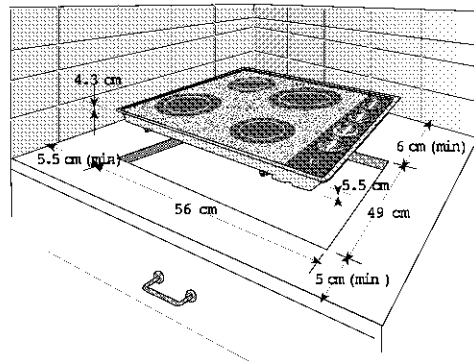
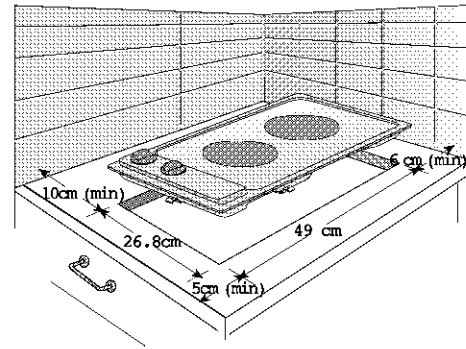

**Attention:** When installing the cooktop above a cupboard, a diving shelf as pictured above must be installed. If installing above an underbench oven this is not required.

### Use of the assembly clamp

**1. If the counter thickness is 2 cm;**

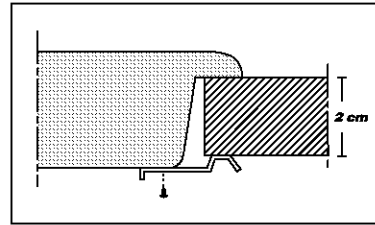

**2. If the counter thickness is 3 cm;**

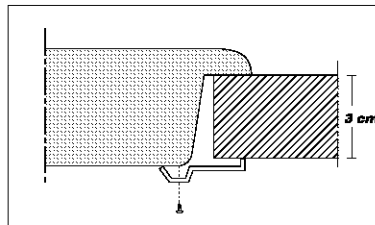

**3. If the counter thickness is 4 cm;**

In this alternative; the assembly clamp will be screwed from the second hole.

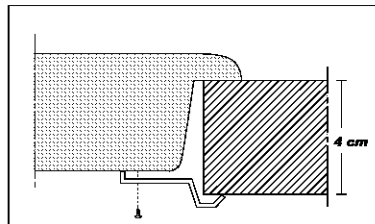

## Part 4: Operating the cooktops

### 4.1 Operating the hot plates

Hotplate control position	Corresponding Cooking Values					
	1	2	3	4	5	6
Application	Warming	Simmering	Cooking-Frying-Boiling			

A rapid heating hotplate is denoted by a red spot in the centre of the hotplate:

#### Hotplate operating knobs

The knobs for the hob can be rotated in either direction to provide fully variable heat control. When any one of the hotplates is on, **the red indicator light on the control panel will be ON.**

In order to switch the hotplate **OFF** turn the corresponding knob to the **0 (zero)** position.

**Check that all the cooker controls have been switched off after use.**

Adjust the hotplates to mid position (3) and leave on for approximately 8 minutes in order to burn off the protective coating on the hotplates. Do not place any pans or other cooking utensil on the hotplates during this process. Fumes will be emitted during the above operation but this is quite normal.

#### Good Quality Pans

Use only good quality pans having a stable bottom as shown below. This results in the maximum use of energy.

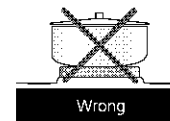
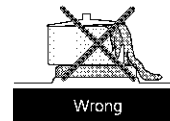
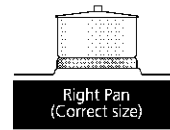

Use pans for the correct diameter only. If the pan is too small, energy is wasted.

Do not place pans with wet bases or pan lids, particularly wet lids on the hotplates damage could occur and safety problem will be experienced.

Hotplate diameter (mm)	Suggested diameter of the pan (mm)
Ø 145 mm (Small)	→ 150-170
Ø 180 mm (Large)	→ 180-200

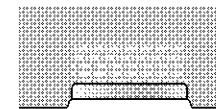
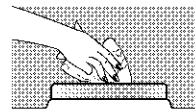

**Drying the hotplates (max 5 min)**

When cool;

Clean off solid hotplates with a damp cloth and a little domestic cleaning cream. After cleaning, dry solid hotplates by switching on for a short time. Apply a thin coat of cooking oil from time to time.

When wiping the hotplates with a damp cloth, follow the circular grooved pattern on the hotplate.

## Cooking guidelines

### Choice of saucepans

For best results we recommend the use of good quality saucepans with smooth flat bases. Aluminium pans with coloured vitreous enamelled bases absorb heat and are therefore more efficient in use.

Never use recessed or ridged base utensils. Ideally the base of the saucepan should be approximately the same size as the heating area. Use pans which have sufficient capacity for the amount of food being cooked and therefore reduce soiling caused by excessive spillage.

### Safety recommendations for deep frying

1. Use a deep pan, large enough to completely cover the appropriate heating elements.
2. Never fill the pan more than the one-third full of fat or oil.
3. Never leave oil or fat unattended during the heating or cooking period.
4. Do not fry too much food at the same time especially frozen food. This only lowers the temperature of the oil or fat too much resulting in greasy food.
5. Always dry food thoroughly before frying and lower it slowly into the hot oil or fat. Frozen foods in particular will cause frothing and spitting if added too quickly.

6. Never heat fat or fry with a lid on the pan.
7. Keep the outside of the pan clean and free from streaks of oil or fat.

### In the unfortunate event of a chip pan fire, or other pan fire:

1. Switch off the electricity supply.
2. Smother flames with a fire blanket or damp cloth.

Burns and injuries are caused almost invariably by picking up the burning pan and rushing outside with it.

**Warning: Do not use water on the fire. Leave the pan to cool for at least 30 minutes.**

## 4.2 Operating the Ceramic hobs

The ceramic hobs are thermostatically controlled with a 6 position switch. One of the stage is the "Off" position. The application field of the six remaining stages are given in table.

Fast radiant, dual or extended type hot plates are energy regulating type. They adjust the burner operation time of the heater continuously between 1st to 3rd stages.

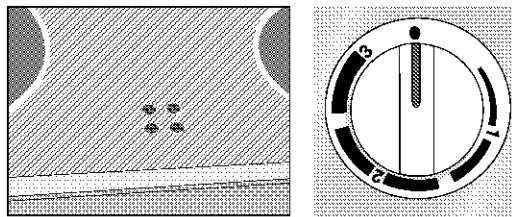

**Hob hot indicator lights**  
Show which hob is operating and/or hot. Indicator lights will remain on whenever the hob is hot. Whenever the temperature of the hob surface falls below 64 °C limit, the indicator light will go off.

Do not touch and keep children away from the heating zones and appliance at all times.



Corresponding cooking values			
Energy regulator stages	1	2	3
7 stages commutator	1	2 - 3	4 - 5 - 6
Application	Position to hold hot	Simmering	Cooking - roasting - boiling

Dual or extended burners are energy regulating type adjusting the operation time of the heater continuous between 1st to 3rd stages. Dual burner can heat up at 2 different positions. Saving energy and time can be achieved by lighting the 1st stage for small pots and the 1st and 2nd stages for large pots. By turning the burner knob clockwise, the inner part of the burner will heat up. You can use the 1st, 2nd and 3rd stages according to the applications indicated in the table. Keep turning the "● ·" knob in a clockwise direction starting from the 3rd stage until a "click" sound is heard to use the interior and exterior parts of the burner at the same time. Both stages of the burner will operate. After the completion of the cooking operation, set the knob to "0" position by turning it in a counterclockwise direction.

**Caution: The 2nd stage of your dual or extended burners will not operate by itself.**

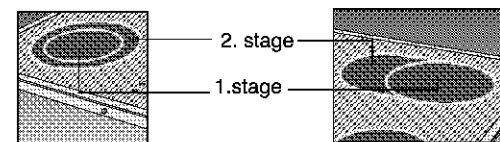

## How to operate vitroceramic hobs

- Ceramic glass surface is highly resistant to heat and excessive temperature differences.
- In order to avoid hob soilage, make sure the bottom of the cooking utensil and ceramic hob surface are clean and dry before use.
- A slight buzzing sound can be heard if any of the hob comes on. This is normal and not a fault.
- Do not use the ceramic glass surface for food preparation, storing or any other non-cooking related purposes.
- Avoid heating up empty enamel pots.
- The scratching or dropping of sharp cornered pots onto ceramic glass surface may cause damage to the surface.

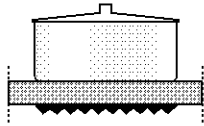

- Optimum efficiency can be achieved by using pans that are suitable for the diameters of the heaters.

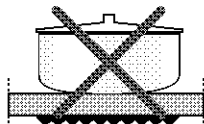

- Pans with convex bottoms are not suitable.

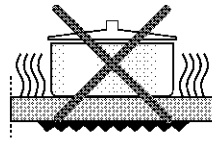

- If the pan is too small energy is wasted.

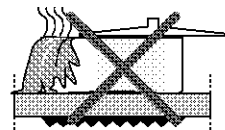

- Splashes may damage the ceramic surface and can cause fire.

- Keep away the children from the heating surfaces which are in operation and therefore have hot surfaces.
- Because heated oil has a tendency to catch fire, cooking greasy food (like French fries) should be carried by utilizing a covered container.
- Do not use pots that have concave or convex bottoms.
- Do not cut bread or slice vegetables, fruit, etc. on top of it.
- Optimum efficiency can be achieved by using pans that are suitable for the diameters of the heaters.
- Do not use aluminum-bottomed pots. (This results in the deterioration of the ceramic glass surface).
- Use steel or heat-resistant glass pots. Do not use pots made from materials such as "boron glass", or "Pyrex", which are generally oven-type containers.
- The diameter of the pot to be used should be no smaller or larger than the diameter of the hob.
- Do not place any material on the ceramic surface, such as plastic, aluminium, etc.
- Materials such as plastic or aluminium material that have melted onto the ceramic surface for any reason should immediately be removed with a hob scraper.
- Never use a dishcloth or sponge to clean the ceramic hob as these may leave a layer of soiled detergent on the hob which will burn and discolour the next time the hob is used.

### Important Warning!

**Immediately switch off the appliance from the mains if a crack is detected on the ceramic glass surface**

## Part 5: Maintenance and cleaning

- Before switching on again ensure that all controls are in the OFF position.
- Make sure that the burners and hot plates are sufficiently cool before you start cleaning.

• It is recommended that the acidic matters such as oil, lemon etc. should be cleaned immediately.

### • **Solid hotplates**

The cleaning of solid hotplates should be done when they are cold, using non scratch cream following the grain of the hotplate. Wipe over with a damp clean cloth, making sure that all the cleaner has been removed. Finally, turn on the hotplate to warm for a few minutes, then smear with a little cooking oil to provide a protective coating.

• **Vitreous enamel hob surround:** Clean with a cloth wrung out in soapy water. Stubborn stains can be removed with a cream, paste or liquid cleaner. Check that the cleaning agent used is approved by the Vitreous Enamel Development Council.

**Knobs should not be removed during cleaning.**

• Never clean the cooker surface by using materials such as hard brushes, steel pads or knives, which can easily scratch the enamelled and stainless steel surfaces. Special cleaners that are commercially available may be used after carefully reading the warning labels written on them. Do not use cleaning agents containing acid or chlorine on stainless steel surfaces. Cleaning can be accomplished using a soft piece of cloth wetted with soapy water or with commercially available special surface cleaners and a soft piece of cloth. Especially use liquid paste or cream type cleaners.

## The Ceramic Glass plates cleaning:

- ☛ Unplug the plug from the power supply during cleaning.
- ☛ Wait for the ceramic glass cool down completely before starting to clean.
- ☛ Be sure to use a cleaning agent that does not contain any particles are pieces that may scratch the ceramic plate surfaces.

**Use cream or liquid cleaning agents.** Do not use mechanical-type powders or detergents as well as bleach-based cleaning agents.

- ☛ Steel wool or brushing may damage the ceramic glass surface.
- ☛ Dust on the ceramic surface may be removed with a moist cloth.
- ☛ The ceramic surface will serve you for many years if you treat it with proper care.
- ☛ Changes in the tint of the ceramic glass surface will not have any effect on ceramic's functional structure or durability
- ☛ The ceramic surface must be wiped off with cold water and dried with a soft piece of cloth.

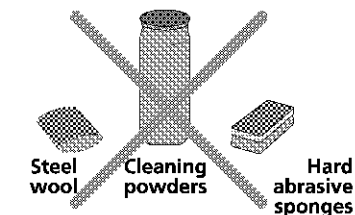

**Do not use the above materials to clean ceramic glass and stainless steel surfaces.**

- ☛ You can use the spatula supplied with the unit in order to remove spilled food and remains from the surface.
- ☛ Sugar-based food such as jam should immediately be removed away with the spatula without waiting for the ceramic glass to cool down. Color change is not due to the change in the material properties, but rather it stems from insufficient cleaning of burnt residue that accumulates on surfaces, abrasion on the glass surface which is caused by pots and pans along with the use of improper cleaning agents.

## Part 6: Future transportation

### ☛ **Transporting the cookers;**

Keep the original carton box transport your product with its original carton box, and obey to the marks printed on the carton box.

### ☛ **If you do not have the original carton;**

Take precaution for the strokes or damages that can occur on the outer surfaces of your product. Do not put a load on the top of the cooker more than its original load.

Pack the vitro-ceramic hob in bubbled nylon or thick cardboard and tape it completely in order to prevent any damage which may be experienced during shipping.

Hold your product up in an upright position during shipping and do not place any cargo on top of it.

## Guarantee

Your Euromaid cooker is guaranteed for twelve months from the date of the original purchase. Any defect that arises due to faulty materials or workmanship will be repaired free of charge during this period. The guarantee is subject to the following provisions.

- The guarantee does not cover accidental or transit damage, misuse, cabinet parts, knobs or consumable items such as light bulbs.
- The guarantee does not cover repairs or service calls required as a result of inexpert or faulty installation.
- The product must be correctly installed and operated in accordance with the instructions contained in the operating instruction booklet.

- The product is designed for domestic use only. The installation of this product on business premises for commercial use will invalidate the guarantee.
- The guarantee is only valid within the boundaries of the Australia.
- The guarantee will be rendered invalid if the product is resold or has been affected by inexpert repair.
- Euromaid disclaims any liability for incidental or consequential damages.
- The guarantee is in addition to and does not diminish your statutory or legal rights.

# ELECTRICAL DISTRIBUTORS AUSTRALIA PTY LTD

ABN 11 051 297 557

SUITE 16 NO./7 NARABANG WAY BELROSE NSW 2085

PH:02 99861699 FAX: 02 99861196 EMAIL:EDAAUST@bigpond.com

## EUROMAID COOKER & HOT PLATE WARRANTY IN ADDITIONS TO RIGHTS BY LAW

Electrical Distributors Australia Pty Ltd guarantees to the original purchaser during the first one or Two Years of ownership (subject to model and type as listed below) that any part with defective material be replaced free of charge, provided that all service work is carried out by Electrical Distributors Australia Pty Ltd or the nearest appointed service agent.

### **Models Subject to 12 months Warranty:**

AD0640, BT180, BT220, MC1110T, SC11531, SCNG7531, SCLPG7531, MDA200  
Any new models released not stated above are also 12 months warranty.

### **Models Subject to 24 months Warranty:**

1505TI, A0975SS, A0985SS, A0980SS.

Where the appliance is installed outside the normal service area of Electrical Distributors Australia Pty Ltd or it's Appointed Service Agent the purchaser will pay the travel cost charges to take the appliance to the service centre.

### **AUTHORISED SERVICE AGENTS:**

#### **NSW**

ALL GENERAL WHITEGOODS  
4/11 HALLSTROM PLACE  
WETHERILL PARK 2164 NSW  
PH: 02 97561511 FAX: 02 97561091

#### **GOLD COAST**

ROSHAD APPLIANCE SERVICE  
1/13 LEDA DRIVE  
BURLEIGH QLD 4220  
PH: 0755357044 FAX:0755357407

#### **VIC**

ADVANTAGE APPLIANCES  
54/170 FORSTER ROAD  
MT WAVERLY VIC 3149  
PH:03 95588044 FAX:0395442102

#### **TASMANIA**

BALDOCKS  
**222 LIVERPOOL STREET**  
HOBART TASMANIA 7000  
PH: 036 22345995 FAX:036 2348134

### **Portable Appliances:**

For Bench top or portable appliances the purchaser must arrange their own transport to our nearest authorised Service Centre, these portable items do not offer in Home Service.

### **Built In Appliances:**

Access must be granted within normal working hours and our Service Agents must have easy access to these built in appliances and charges will be the responsibility of the purchaser where the service technician can not obtain easy access to remove the appliance for inspection prior to repair.

This Warranty is not transferable and excludes any repair or replacement caused by Power Surges faulty installation abuse, Pest Damages, misuse, acts of God or accident.

The above Warranty is for Domestic application only is limited to THREE (3) Months in Commercial Applications.

#### **WESTERN AUST.**

METROPOLITAN APPLIANCES  
15 SHIELDS CRESCENT  
MY AREE WA 6154  
PH: 089 3301724 FAX: 089 3171296

#### **SOUTH AUST.**

PRESTIEGE APPLIANCE REPAIRS CENTRE  
SHOP 4/394 HENLEY BEACH ROAD  
LOCKLEYS SOUTH AUSTRALIA  
PH: 088 352202 FAX: 088 3522044

#### **QUEENSLAND**

ENDEAVOUR REFRIGERATION  
167 ROBERTS ROAD  
FORTITUDE VALLEY QLD 4006  
PH: 073 8522477 FAX: 073 8532467

**FOR SERVICE OUTSIDE THE ABOVE AREAS PLEASE CONTACT HEADSYDNEY OFFICE PH:02 99861699**

185.9248.11/R1/23.02.2004