

PRODUCT & TECHNICAL SHEET

Brand

EUROMAID



Model Number : CS80S, CS80WH
Model Description : Euromaid 80mm Slidedout
Colours : White, Stainless Steel
Sizes : 600mm

SPECIFICATIONS

TECHNICAL DATA :

- 40 watt incandescent light
- Axial 2 speed motor 43 watt
- 240 Volt / 50 Hertz
- Tested to EMC AS/NZS4417 (radio frequency interference)
- Electrical approval AS3310-1992
- Performance tested to AS2682-1984

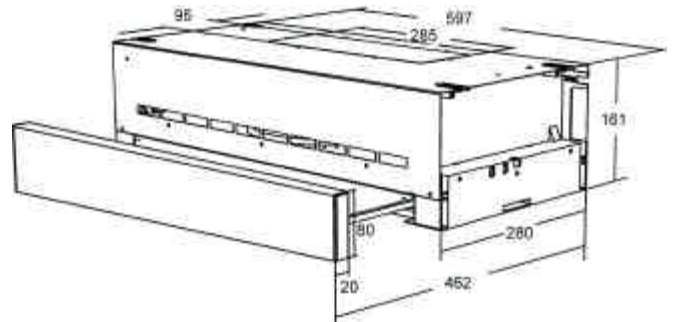

WEIGHT (kg) :

600mm 6.32kg

Rangehood Dimensions:

CARTON DIMENSION (mm) :

310 x 185 x 615 (600 unit)

280 x 161 x 597 (600 unit)

Volume (m³) :

0.035m³

PERFORMANCE DATA :

	Max Airflow (m/hr ³)	Noise (dB)
Speed 1	250	56
Speed 2	385	62

FEATURES AND BENEFITS

FEATURES

- 2 speed control
- Recirculating installation
- Duct exhaust options
- Single charcoal filter option
- 80mm Front handle
- Light/speed controls underneath the unit
- High performance axial fan
- One touch slide action
- Safety thermal overload switch
- Fire retardant plastic parts

BENEFITS

- Adjustable speed control to suit your cooking requirements
- Rangehood does not have to be ducted saving n installation costs
- Ability to remove odours and grease outside your kitchen
- Removes cooking odours and grease particles
- Already made for recirculating mode
- Easily able to access both controls with safety
- Moves large volumes of air
- Smooth and effortless
- Provides peace of mind by automatically switching off if a fire occurs and thereby prevents they fire being sucked up into the ceiling
- Safety

